



OpenOffice.org can speak using odt2daisy !

Vincent SPIEWAK



Open Accessibility
Everywhere

Groundwork, Infrastructure, Standards



- Accessible document
- DAISY
- Odt2daisy
- Demos
- Questions

Print disabled:

- Visual
- Physical
- Perceptual
- Developmental
- Cognitive
- Learning

- ~~Audio Tapes~~
- Audio CD
- Large Printing book
- Braille book
- DAISY book

- Digital Accessible Information SYstem
- Standard
- Consortium
- Format
- Book



- Navigation
- Bookmarks
- Skim the text
- Portable

DAISY XML

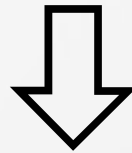

- Audio CD
- Large Printing
- Braille
- HTML
- Full DAISY (Text + Audio)

The screenshot displays the DAISY Pipeline application window. The interface is divided into three main sections: Jobs, Progress, and Messages.

Jobs Panel: Shows a list of jobs. The 'TTS Narrator (DAISY XML to DAISY Book)' job is currently selected and highlighted in blue.

Progress Panel: Displays the status of the selected job, 'TTS Narrator (DAISY XML to DAISY Book)', which is 'Running'. It provides a detailed breakdown of progress for each step:

Step	Progress	Time
Structure announcer	6/14	Done in 485 ms
XML Detection	7/14	Done in 069 ms
Mixed Content Normalizer	8/14	Done in 119 ms
SpeechGen2	9/14	20 s 813 ms left

Messages Panel: Shows a log of messages related to the job:

- Copying referenced files
- Input document has 73 elements
- 3 wrapper element inserts were done to input document during normalization.
- 31 synchronization points were located and marked in input document.

Victor Stream, Plectalk, Bones ...



AMIS, Emerson Reader, Buttercup, ghPlayer



- Author : Vincent Spiewak
- GodFather : Peter Korn
- Supervisor :
 - Jan Engelen
 - Christophe Strobbe
- <http://odt2daisy.sf.net>

- open Accessibility Everywhere:
Groundwork, Infrastructure, Standards
- Funded by a grant awarded by the
European Commission
- 20 organisations
- Several technical objectives
- <http://aegis-project.eu>

- Started in January 2008
- Gold Award from the OpenOffice.org Community Innovation Program 2008 (sponsored by SUN Microsystems, Inc)
- BrailleNet, CUCAT, AMAC, ABWA, Wyoming Department of Education, ...

- Opensource LGPL 3.0
- Features
 - DAISY XML 3.0
 - Full DAISY 2.02 and 3.0
- Platforms
 - Windows
 - Mac OS X
 - Linux
 - Solaris / Open Solaris

- Cross platform
- Simple to install
- Simple to use
- Code reusable
- No OOo dependancies
- Conversion parameters

- Package
 - Command line tool
 - JAR
 - OpenOffice.org Extension
 - (Pipeline)
- Requirement
 - Java 5 (or +)
 - OpenOffice.org 3.0 (for addon)

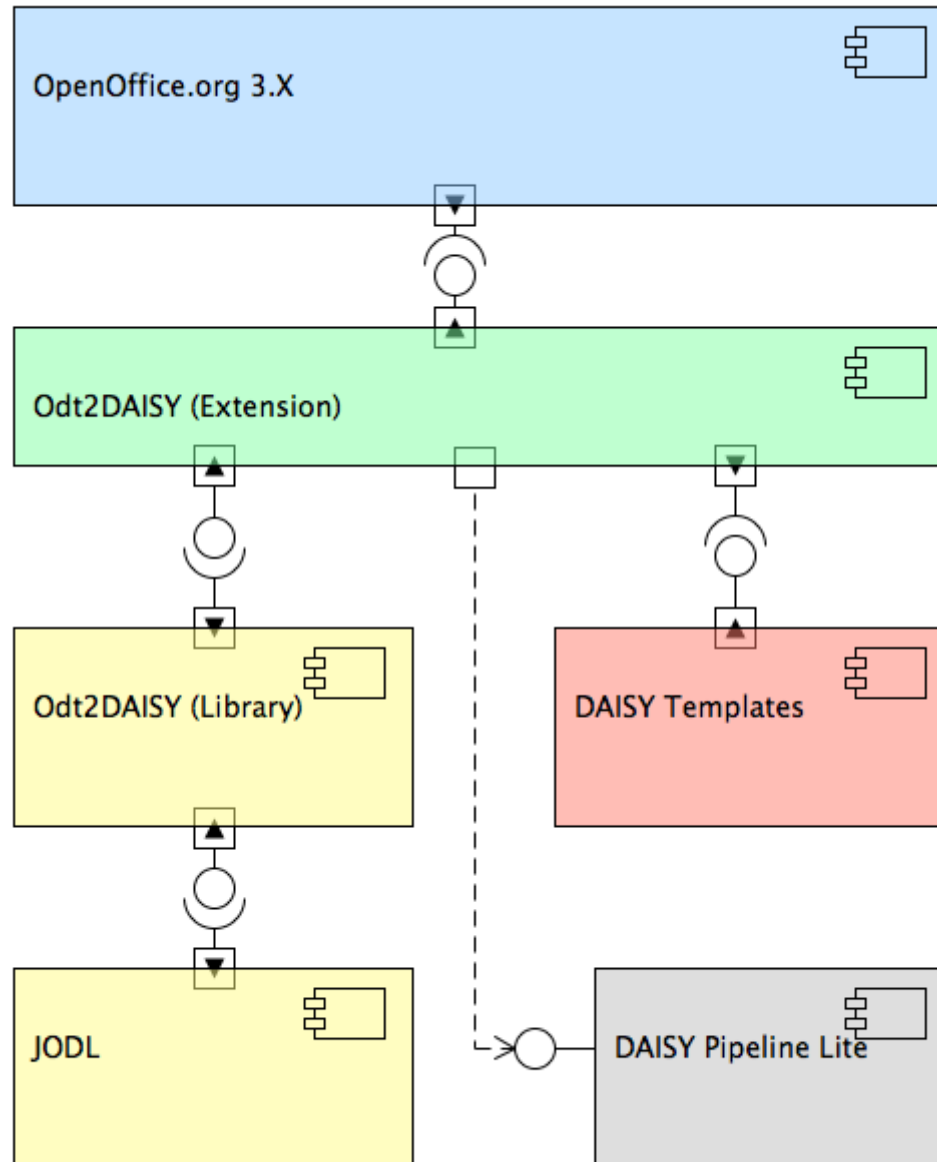

- Dependancies
 - Lame / Sox static compilation
 - Universal Binaries (Lipo)
- Uniformisation
 - Build Mac OS X (PowerPC/Intel)
 - Build Linux
 - Build Solaris / Open Solaris (x86/Sparc)
- Integration
 - Zip
 - JNA

- Heading, List, Table, Images, Captions, Notes, Foot/Rear notes, Math, TOC, Section, Frame, Bookmark, Metadata, ...
- Language (no Asian/CTL)
- Page Numbering (1,i,I,a,A / advanced)
- Custom Styles
- Front / Body / Rear Matter

- Windows
 - English / ~~Chinese~~
 - SAPI 5 Voices
(Cepstral, Infovox, Dolphin, ...)
- Mac OS X
 - English (Alex, Vicky, ...)
 - Voice Over
(Cepstral, Infovox, ...)
- Linux / (Open)Solaris
 - Up to 27 languages (espeak)
 - Loquendo, IBM TTS

- Development
 - Unit Testing
- Users
 - DTD Validation (DAISY XML)
 - ZedVal (Full DAISY)

- Instruction Manual
ODT / PDF / DAISY XML / Full DAISY
- Screencasts
- Forum
- Bug Report

[DEMOS]



- No alting
- JEuclid crash (issue 92926)

```
<style:style style:name="P1"  
    style:parent-style-name="Standard">  
    <style:text-properties fo:country="US"  
        fo:language="en" />  
</style:style>  
  
[...]  
  
<text:p text:style-name="P1">  
    Some English with some chinese 制 .  
</text:p>
```

- DAISY Structure
- ODF Structure

- Bugfix
- MP3 Player
- MathML alttext
- Cloud (?)
- Acronym / Abbreviation
- Accessibility Checker
- ...

- Bug Report
- Localisation
 - User Interface
 - Documentation
- Improvement
 - odt2daisy
 - eSpeak voices
- Donation

Vincent Spiewak
vspiewak@gmail.com

Any question ?

Thank you :)